

UNEX™ P

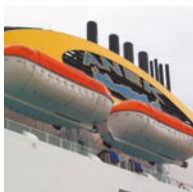
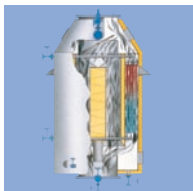
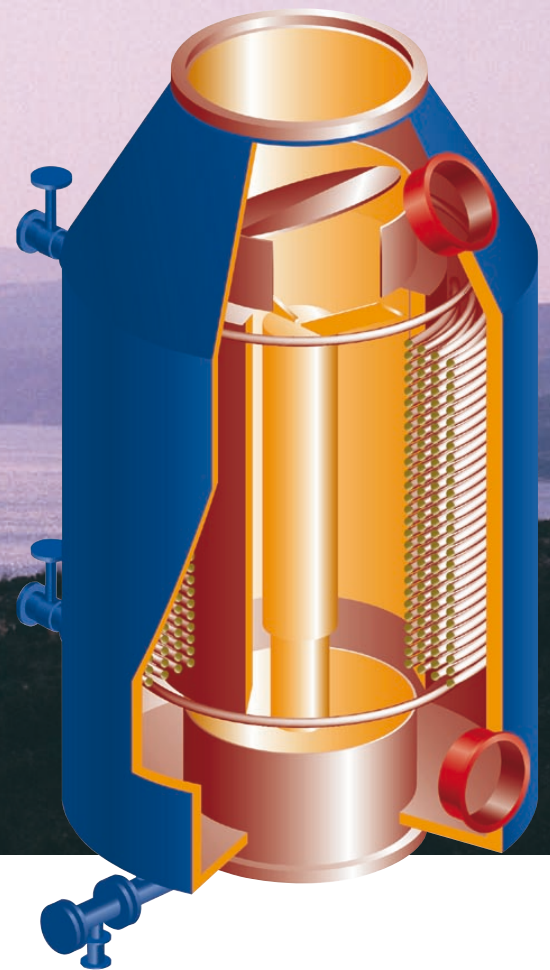

The UNEX™ P multi-function exhaust gas economizer is a bare water tube, forced circulation economizer for steam or hot-water applications.

Steam generating capacity:
0.5-5.0 t/h

Hot-water capacity:
400-2,800 kW

Standard design pressure:
10-16 bar(g)

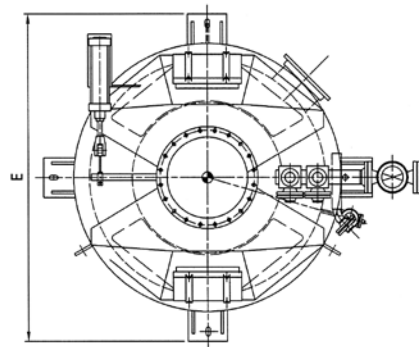
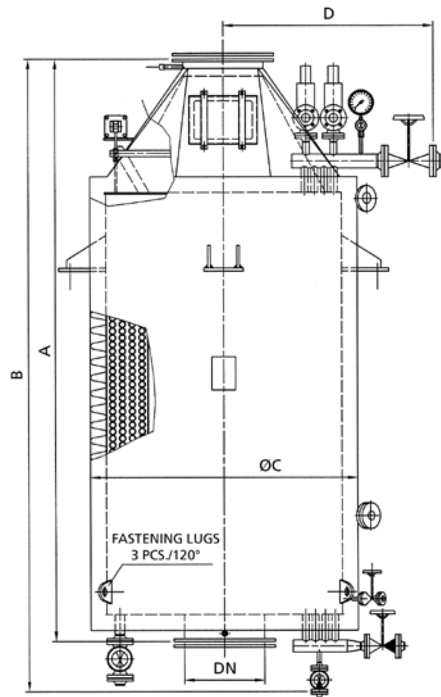

Sketch of typical UNEX™ P economizer.
Each economizer is tailor-made to suit the engine data.

Description

UNEX™ P multi-function exhaust gas economizer is a water tube, forced circulation economizer for heat recovery from diesel engine exhaust gas.

The heat transfer surface consists of vertical, concentric, parallel steel tube coils connected to inlet and outlet manifold pipes.

The rounded shape of the gas-tight steel shell surrounding the tube coils is ideal to withstand exhaust gas pulsations from the engine.

Sound absorber and by-pass duct are located inside the tube coils. The sound absorption effect with basic construction is approx. 20 dB(A).

Vertical and straight exhaust gas passages between the tube rows – together with plain tube construction – decrease soot build-up on heating surfaces. This construction runs without problems even in the most demanding operating conditions. The economizer is equipped with a stationary water washing and steam soot cleaning system.

Features

- Compact system with plain tubes
- Easy and quick to install
- User-friendly operation with integrated, continuous and fully automatic capacity control system
- Built-in water trap
- Built-in water washing device and steam soot blowers as standard equipment

- Built-in sound absorber
- Built-in spark arrester

Scope of supply

- The economizer is supplied complete with connections, exhaust gas cones with counterflanges, lifting and fastening lugs and insulation with sheeting.
- Valves and fittings for the economizer including manual steam sootblowers and fixed water washing device.
- Bolted hatches for maintenance and easy-access inspection doors.
- Spare parts according to class.

Accessories (Optional)

- Silencer can be integrated
- Dumping condenser
- Continuous automatic capacity control