

# WIESLOCH™ TF

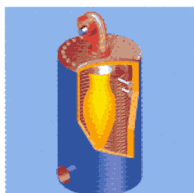
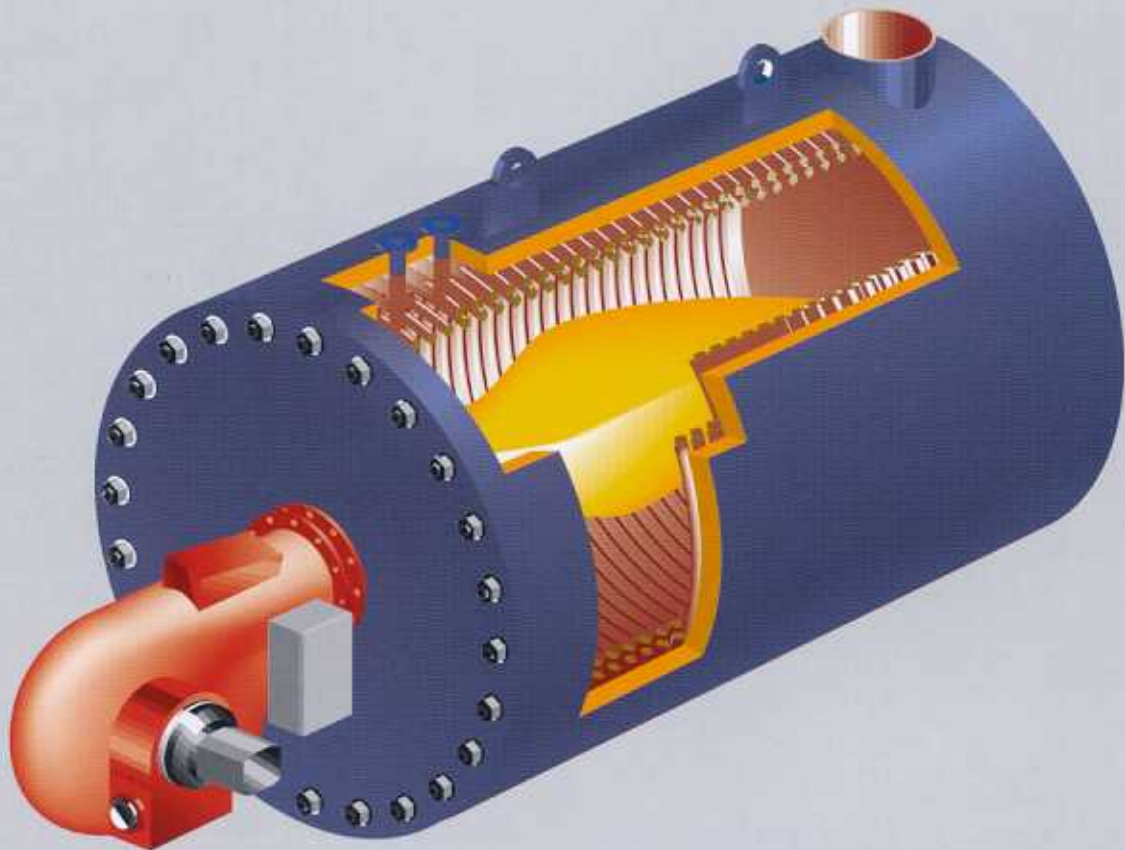

WIESLOCH™ is a standard heavy fuel oil, diesel oil or gas-fired thermal fluid heater. The three-pass flue-gas configuration results in high efficiency. Plain tubes and high flue gas velocity produce a high self-cleaning effect. Due to the large furnace the flame is able to burn fully and does not impinge the furnace tubes.

### A thermal fluid heater of your choice

Aalborg Industries' heating systems are well known for their high standard and quality. Our systems are applied throughout the world in all sectors of industrial process heating.

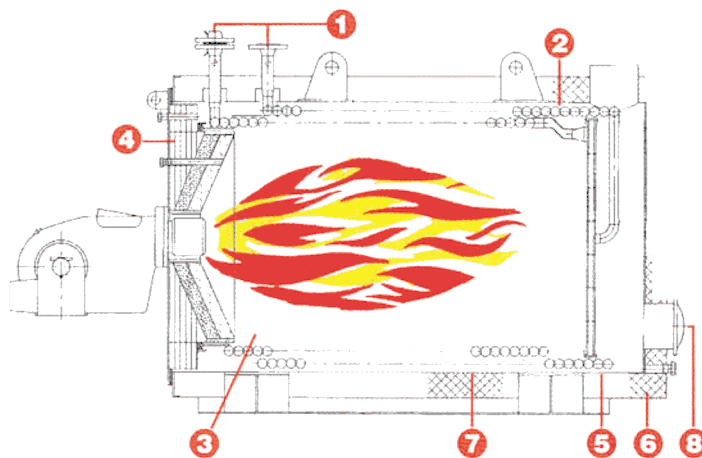

### Advantages of the design

1. Low thermal fluid flow resistance
2. High flue gas velocity, resulting in a good heat transfer
3. Triple draw flue gas principle
4. Removable front cover
5. Gas-tight welded inner jacket of ST. 37 or HII
6. Thick insulated jacket minimizes radiation loss
7. Outer jacket of steel plate.
8. As option we can offer an inspection hole

### Quality

More than a commitment to unflinching performance, our approach to quality reflects a deep respect for our customers businesses.

Only in this way we can sustain our growth and meet market demands.



### Standard unit

*Aalborg Industries' thermal fluid heater delivered as a skid mounted unit - easy to install.*

### Customer benefits

- Standard vertical and horizontal construction
- High efficiency
- Suitable for oil and gas as burner fuel
- Suitable for water, mineral and synthetic oil.
- Low film temperature, ensures long life of the thermal fluid
- Easy to operate
- Low maintenance cost
- Clean and safe

### Engineering and delivery in one hand

Aalborg Industries can provide a complete thermal fluid installation to any industry and ensure that the heat generation fully meets the demands of the heat consumers. An easily adjustable system with a high accuracy of temperature control.

### Thermal fluid or steam?

Aalborg Industries can, as a recognised advisor within steam and thermal fluid heat technology, give you the best qualified and impartial advice regarding the optimal solutions for your business.

### Delivery program

- Thermal fluid heaters
- Burners
- Stacks
- Economisers
- Heat exchangers
- Control panels
- Expansion tanks
- Drain tanks
- Valves
- Circulation pumps

### Your thermal fluid contact:

Aalborg Industries NL B.V.  
P.O. box 145  
3200 AC Spijkenisse  
The Netherlands  
Tel.: +31 181 650 500  
Fax: +31 181 650 501  
E-mail: [rtmw@aalborg-industries.nl](mailto:rtmw@aalborg-industries.nl)  
<http://www.aalborg-industries.com>